

Filtek FT020

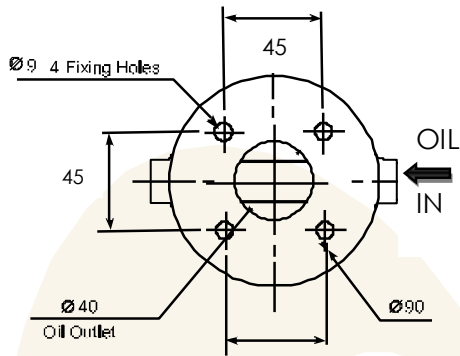

All measurements are in mm unless otherwise stated

Minimum Height for Servicing

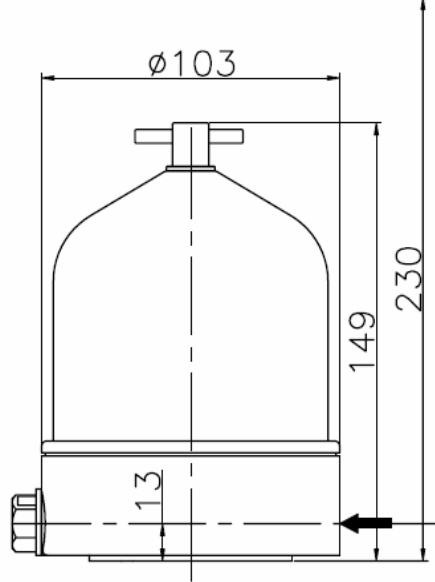

- Suitable for system capacity from 8 to 15 litres
- Rotor dirt capacity 0.16 litres
- Rotor oil capacity 0.20 litres
- Minimum oil feed pipe size 6 mm internal diameter
- Minimum oil drain pipe size 20 mm internal diameter
- Available with or without cut off valve (C.O.V.)

PERFORMANCE CURVES

Typical rotor performance for SAE 30 OIL @ 75°C

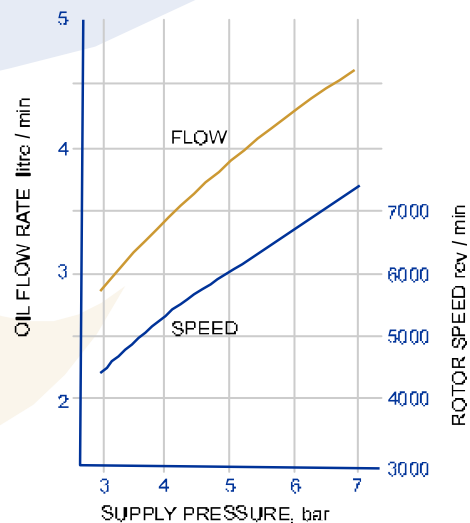

Filtek (India) Pvt. Ltd.

S. No. 321, Unit No. 2, Patil Industrial Estate, Bavdhan (Bk.), Pune - 411 021 INDIA

Telefax : +91 20 22952828

E-mail : enquiry@filtekindia.com