

Filtek FT600

All measurements are in mm unless otherwise stated

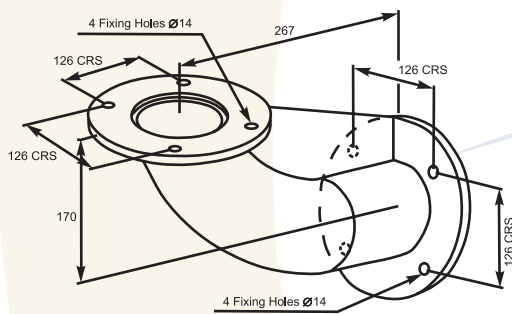

- ❑ Suitable for system capacity over 400 liters
- ❑ Rotor dirt holding capacity 6 liters
- ❑ Rotor oil capacity 6.5 liters
- ❑ Minimum oil feed pipe size 19mm internal diameter
- ❑ Minimum oil drain pipe size 76mm internal diameter
- ❑ Oil inlet threads and Cut Off Valve (C.O.V.) ratings can be tailored to suit customer requirements
- ❑ Rotor disassembly tool is required to service this product
- ❑ The net weight of the FT600 is 25kg.

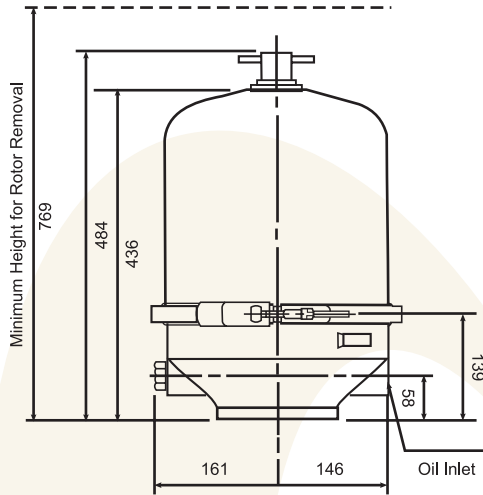
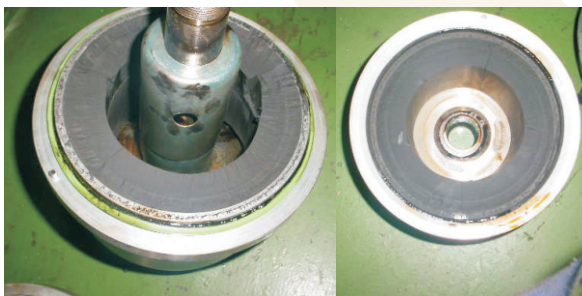

PERFORMANCE CURVES
Typical rotor performance for SAE 30 OIL @ 75°C

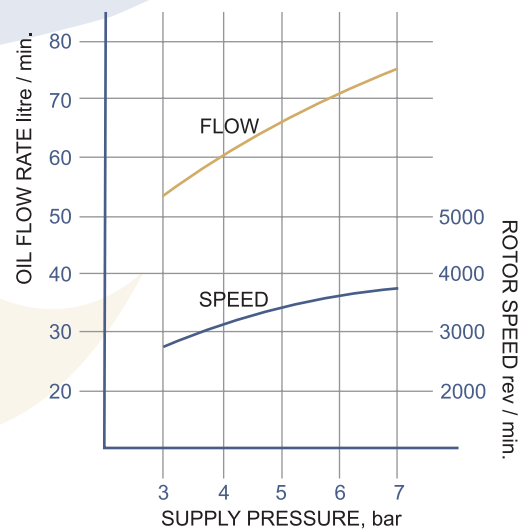

Filtek (India) Pvt. Ltd.

S. No. 321, Unit No. 2, Patil Industrial Estate,
Bavdhan (Bk.), Pune - 411 021 INDIA
Telefax : +91 20 22952828
E-mail : enquiry@filtekindia.com
URL : www.filtefiltration.com